

FAIST Anlagenbau

Noise Control for Road and Industry

**Aluminium Systems
Transparent Systems**

Product Overview Noise Barrier Panels

- Aluminium acoustic panel one-sided highly absorbent
type FAIST Street A2-EH
type FAIST Street A3-EH
- Aluminium acoustic panel double sided highly absorbent
type FAIST Street 3-DH
- Transparent acoustic panel
type FAIST Street T1-K
- Transparent sound barrier wall
type FAIST View
- Safety rope

Installation of sound barrier wall FAIST Street A2/A3

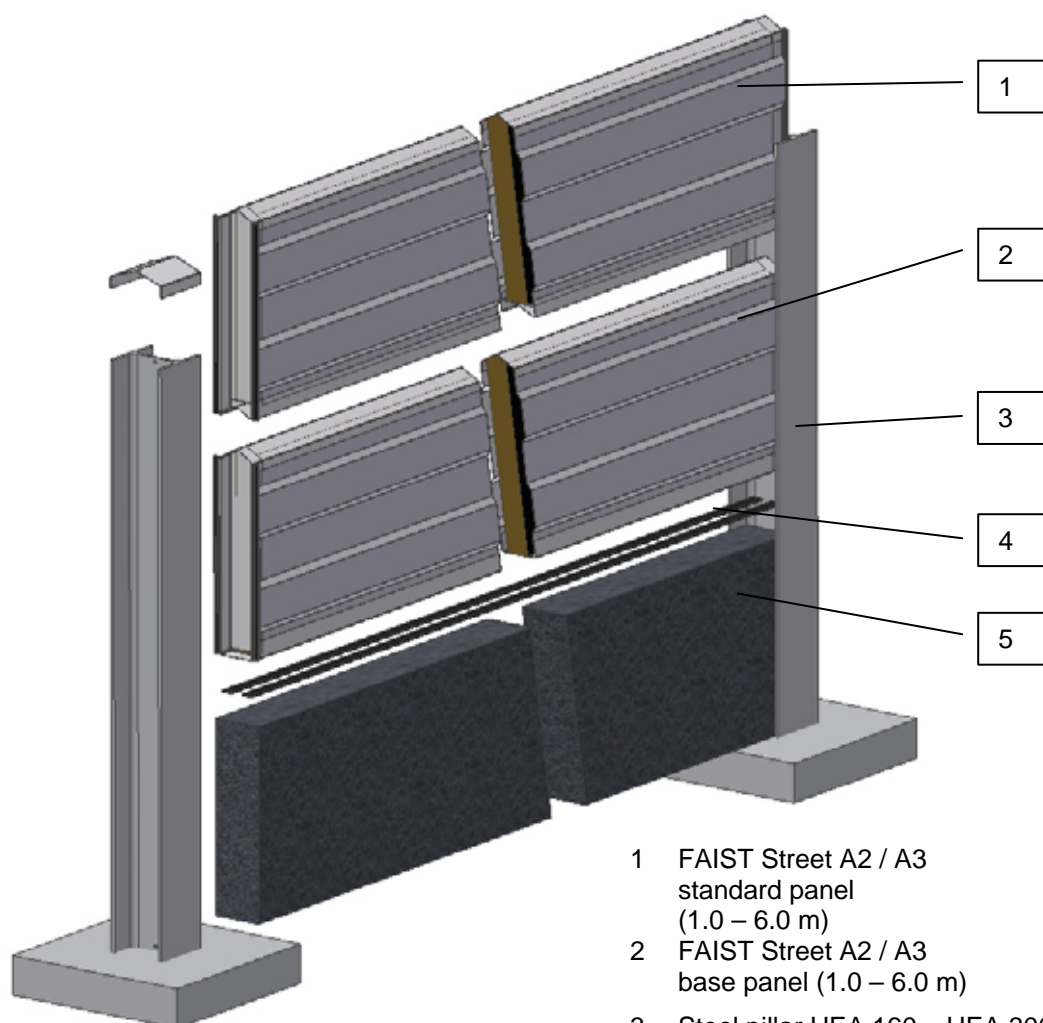

- 1 FAIST Street A2 / A3 standard panel (1.0 – 6.0 m)
- 2 FAIST Street A2 / A3 base panel (1.0 – 6.0 m)
- 3 Steel pillar HEA 160 – HEA 300, optionally also HEB/HEM
- 4 2 compression strips
- 5 Base panel (concrete)

HEA 160

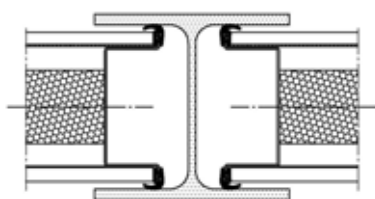

HEA 180

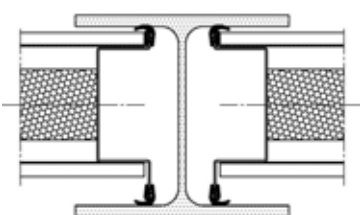

HEA 300

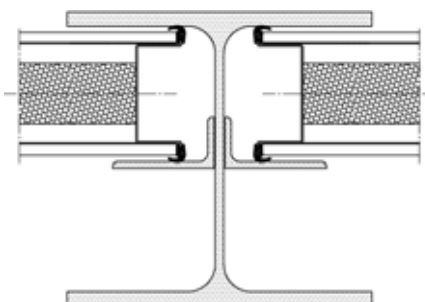

Type: FAIST Street A2-EH

One-sided highly absorbent sound barrier panel (for high wind loads)

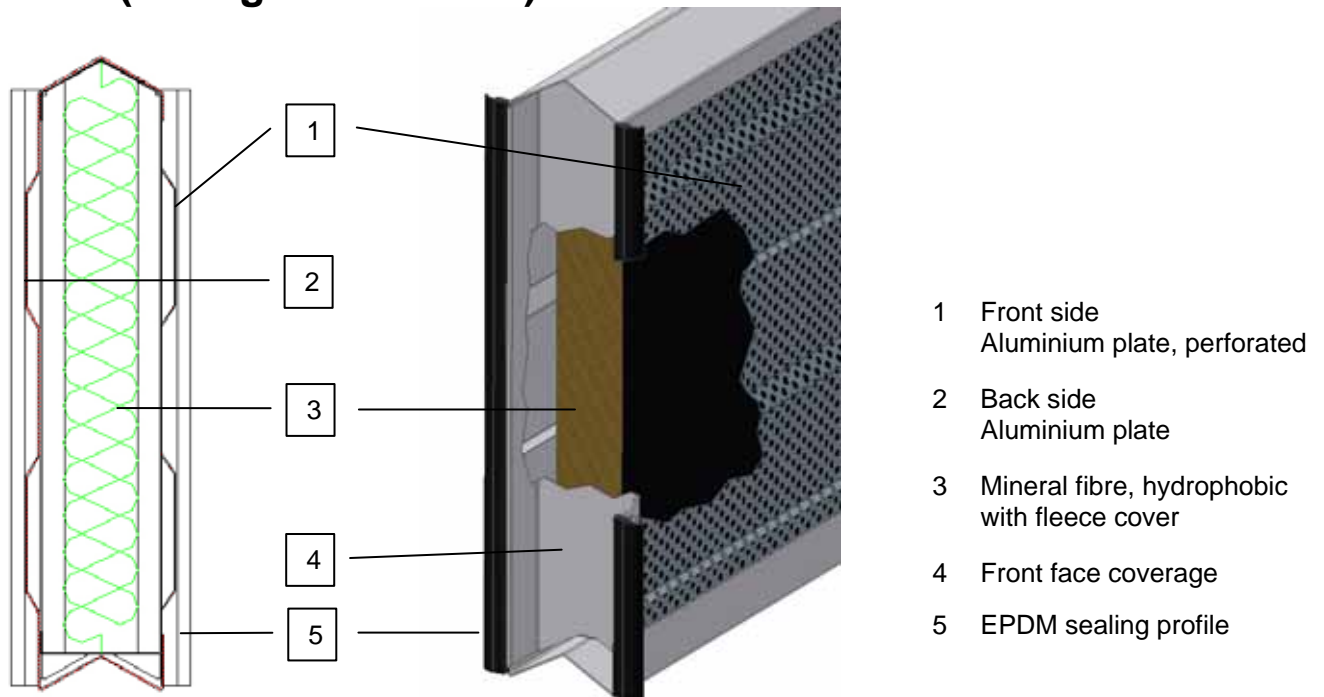

Basic material:

Aluminium, powder coating on polyester basis, free of plumb and chromate. With our paint system, we guarantee the best surface quality and high mechanical durability with maximum environmental protection. Graffiti resistant coating.

Description:

Sound-proofing panel one-sided highly absorbent, according to ZTV-LSW 88, ZTV-LSW 06, EN 1793 1-3 und EN 1794 1-2, facing and back wall provided with two corrugations.

60 mm thick mineral-fibre board, room-weight ca. 100kg/m³, front-side covered with a black fibre (hydrophobic).

Face sides made of folded aluminium plate, vertical sealing with EPDM profile.
Fitting in steel pillar HEA-160 (with intermediate profile up to HEA 300)

Pillar interspace:

1.0 – 6.0 m (please consider permissible wind loads)

Weight:

Approx. 17 kg/m²

Noise absorption:

DL_A = 14 dB,
Absorber group: A4 (acc.to DIN EN 1793-1:1997)
Highly absorbent (acc. to ZTV-Lsw06:2006)
Report n° 122 007 04P-145/2
dated 09.03.2010
Hochschule für Technik Stuttgart

Airborne noise reduction:

R_w (C; C_{tr}) = 31 (-2; -6; -1; -6) dB
DL_R = 25 dB
Airborne noise reduction group: B3
Report n° 122 007 04P-145/1
dated 09.03.2010
Hochschule für Technik Stuttgart

Type: FAIST Street A3-EH

One-sided highly absorbent sound barrier panel

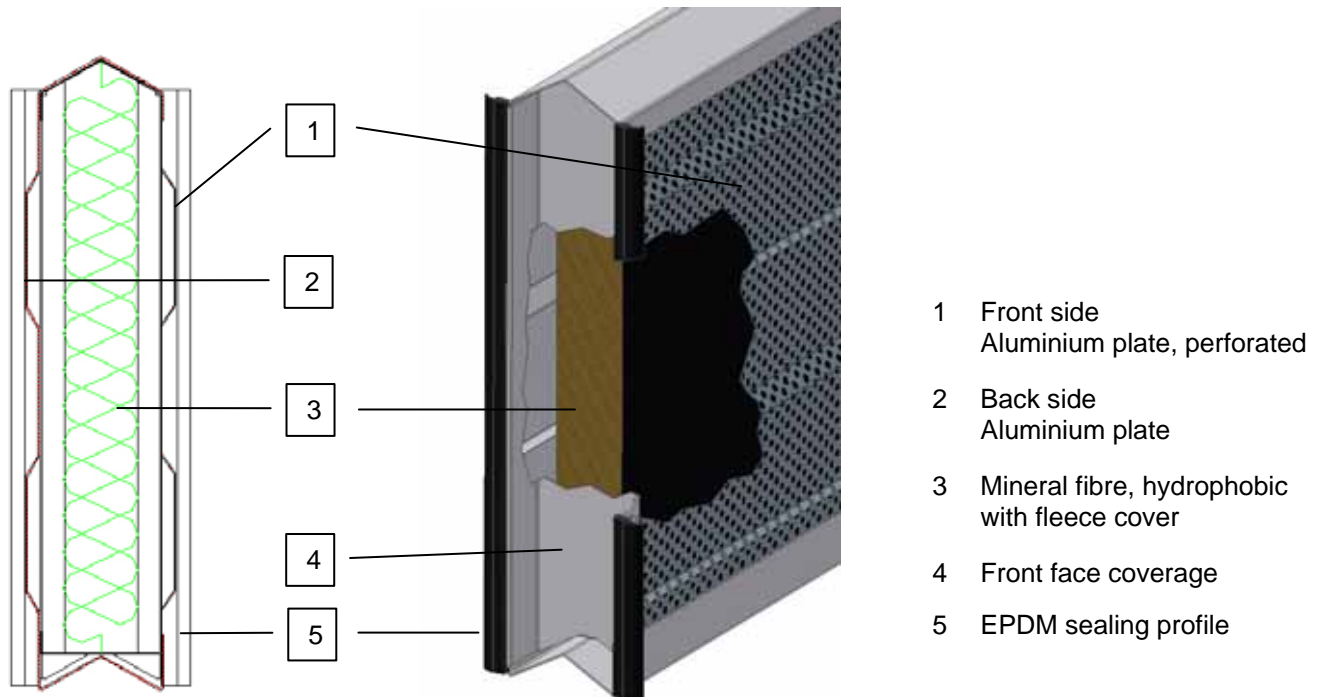

Basic material:

Aluminium, powder coating on polyester basis, free of plumb and chromate. With our paint system, we guarantee the best surface quality and high mechanical durability with maximum environmental protection.

Description:

Sound-proofing panel one-sided highly absorbent, according to ZTV-LSW 88, ZTV-LSW 06, EN 1793 1-3 und EN 1794 1-2, facing and back wall provided with two corrugations.

60 mm thick mineral-fibre board, room-weight ca. 100kg/m³, front-side covered with a black fibre (hydrophobic).

Face sides made of folded aluminium plate, vertical sealing with EPDM profile.
Fitting in steel pillar HEA-160 (with intermediate profile up to HEA 300)

Pillar interspace:

1.0 – 6.0 m (please consider permissible wind loads)

Weight:

Approx. 16 kg/m²

Noise absorption:

$DL_A = 14$ dB,
Absorber group: A4 (acc.to DIN EN 1793-1:1997)
Highly absorbent (acc. to ZTV-Lsw06:2006)
Report n° 122 007 04P-145/2
dated 09.03.2010
Hochschule für Technik Stuttgart

Airborne noise reduction:

$R_w (C; C_{tr}) = 31 (-2; -6; -1; -6)$ dB
 $DL_R = 25$ dB
Airborne noise reduction group: B3
Report n° 122 007 04P-145/1
dated 09.03.2010
Hochschule für Technik Stuttgart

Typ: FAIST Street A3-DH

Double-sided highly absorbent sound barrier panel

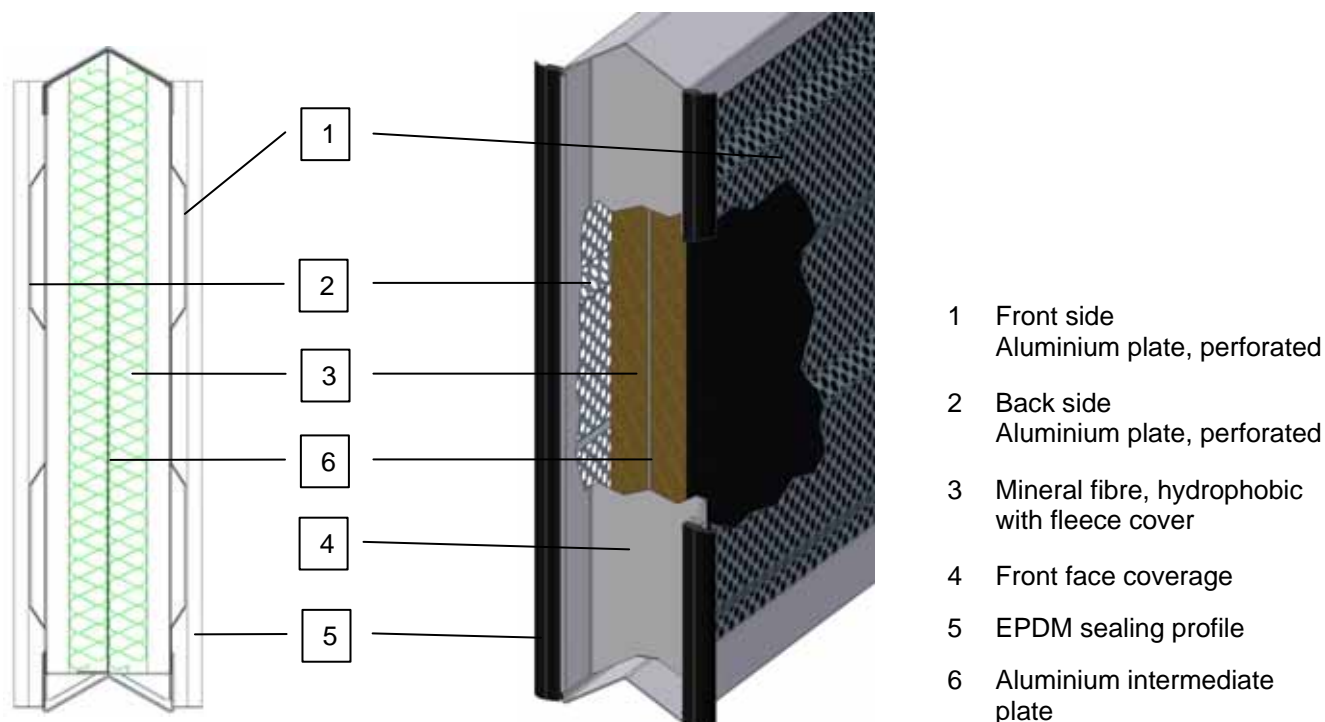

Basic material:

Aluminium, powder coating on polyester basis, free of plumb and chromate. With our paint system, we guarantee the best surface quality and high mechanical durability with maximum environmental protection.

Description:

Sound-proofing panel double-sided highly absorbent, according to ZTV-LSW 88, ZTV-LSW 06, EN 1793 1-3 und EN 1794 1-2, front and back wall provided with two corrugations.

2 x 40 mm thick mineral-fibre sheet, room-weight ca. 100kg/m³, front-side covered with a black fibre (hydrophobic).

Face sides made of folded aluminium plate, vertical sealing with EPDM profile.
Fitting in steel pillar HEA-160 (with intermediate profile up to HEA 300)

Pillar interspace:

1.0 – 6.0 m (consider the permissible wind loads, please)

Weight:

ca.19 kg/m²

Noise absorption*:

DL_A = 8 dB,
Absorber class: A3

Airborne noise reduction:

R_w (C; C_{tr}) = 31 (-2; -6; -1; -6) dB
DL_R = 25 dB
Airborne noise reduction group: B3

Permissible wind loads for noise barrier panels $l/h \geq 10$

FAIST Street A3-EH

Panel type	Pillar distance [mm]	Maximum permissible wind load [kN/m ²]	Wind zone according to DIN 1055-4, scheme 2, $h \leq 10m$	Zone according to DIN 1055-4, scheme 9			
				A	B	C	D
STREET A3-0S-EH	2000	1.6	1		X	X	X
			2				X
STREET A3-1S-EH	3000	2.9	1	X	X	X	X
			2		X	X	X
STREET A3-0S-EH	3000	1.0	1				X
			2				
STREET A3-1S-EH	4000	1.9	1		X	X	X
			2			X	X
STREET A3-0S-EH	4000	1.0	1				X
			2				
STREET A3-1S-EH	5000	1.3	1			X	X
			2				X
STREET A3-1S-EH	6000	1.1	1				X
			2				

Reinforced version: FAIST Street A2-EH

Panel type	Pillar distance [mm]	Maximum permissible wind load [kN/m ²]	Wind zone according to DIN 1055-4, scheme 2, $h \leq 10m$	Zone according to DIN 1055-4, scheme 9			
				A	B	C	D
STREET A2-0S-EH	2000	3.1	1	X	X	X	X
			2		X	X	X
STREET A2-1S-EH	3000	2.9	1	X	X	X	X
			2		X	X	X
STREET A2-0S-EH	3000	2.4	1		X	X	X
			2		X	X	X
STREET A2-1S-EH	4000	2.5	1		X	X	X
			2		X	X	X
STREET A2-0S-EH	4000	2.2	1		X	X	X
			2		X	X	X
STREET A2-1S-EH	5000	1.5	1			X	X
			2				X
STREET A2-1S-EH	6000	1.1	1				X
			2				

Structural integrity of types tested by LGA Augsburg, report dated 02.09.2010

Installation Acoustic Panel FAIST Street T1-K

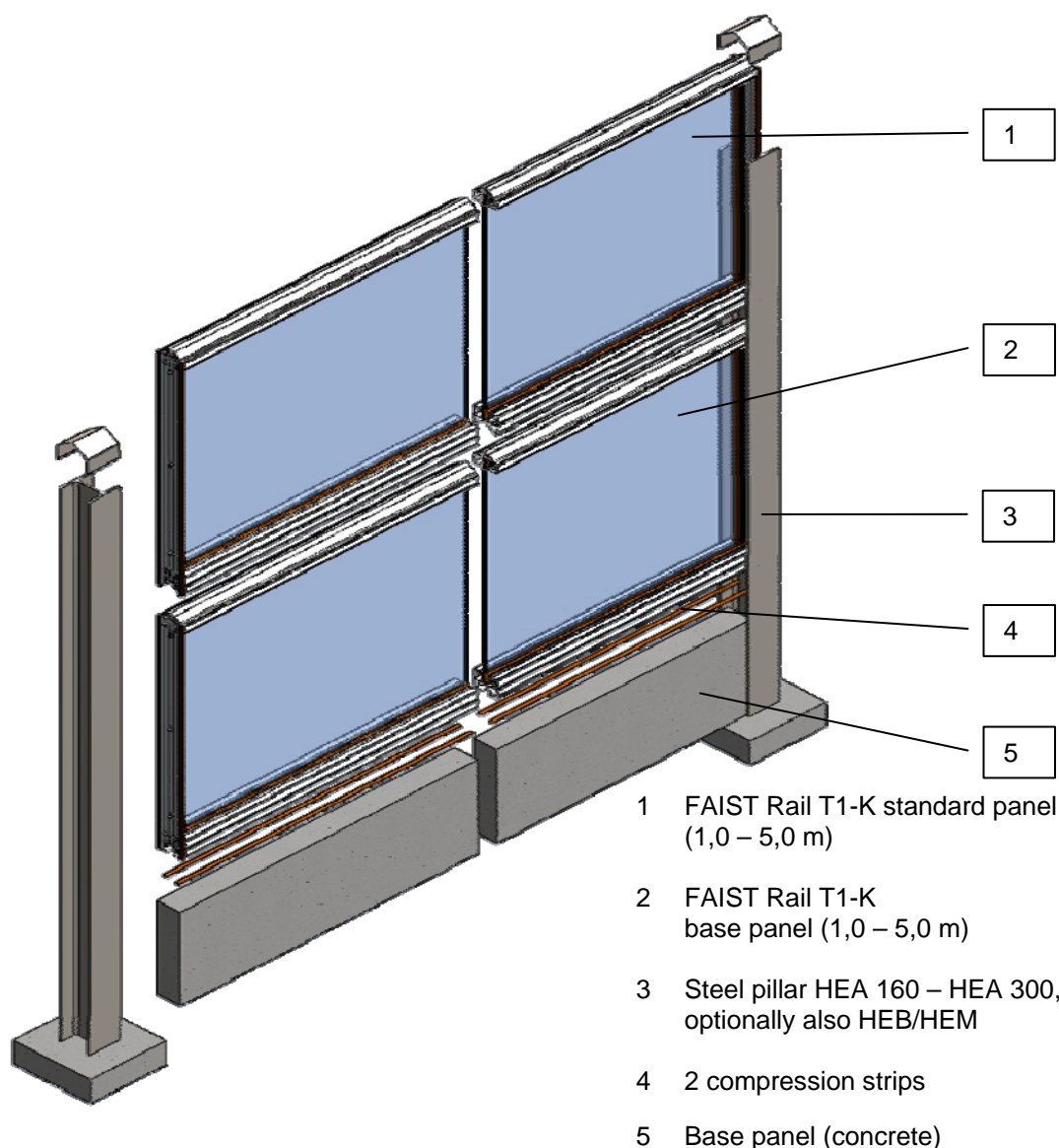

Installation samples:

HEA 160

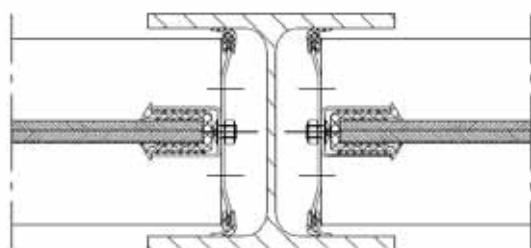

other

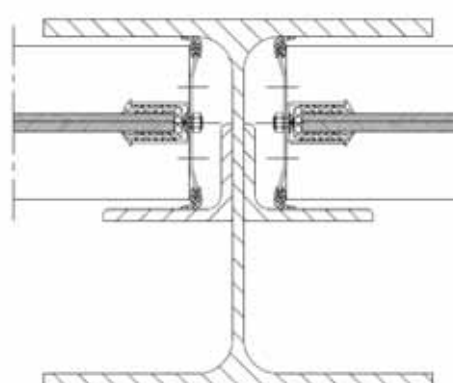

Installation FAIST Street T1-K:

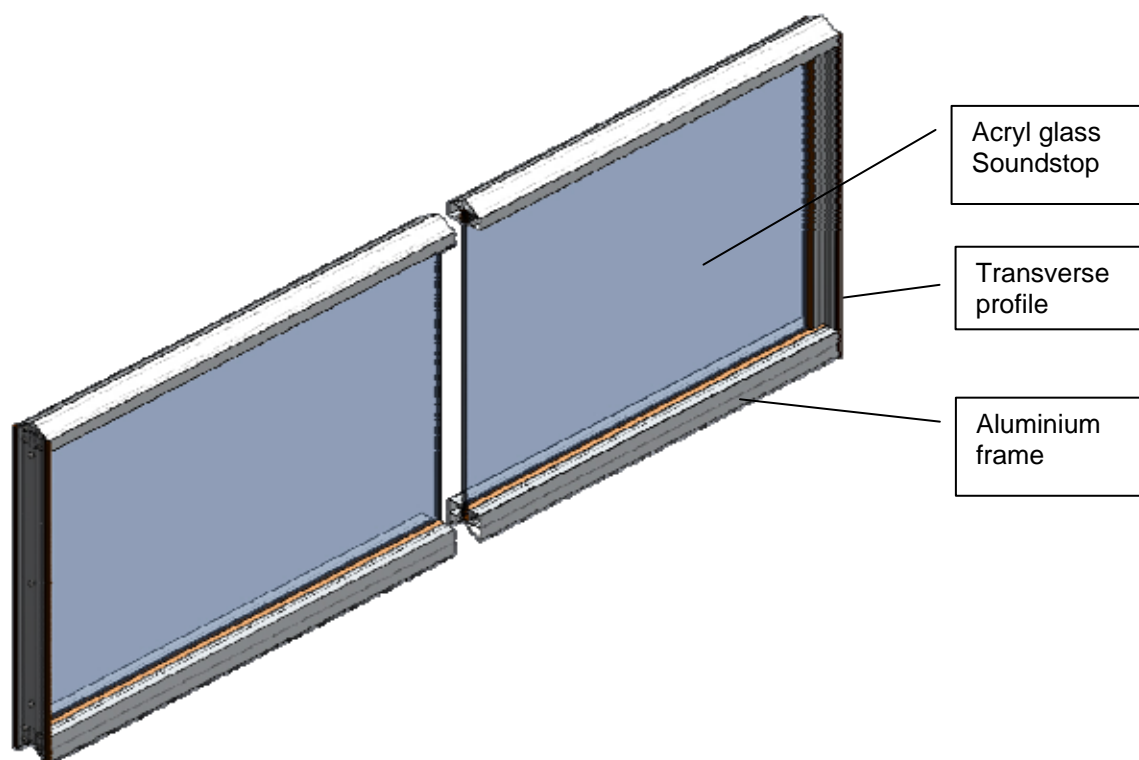

Dimensions:

Panel thickness:	122mm
Standard height:	Standard 1000 mm Each height between 500 mm and 1000 mm possible
Panel length:	Standard 5m Each length between 0,5m and 5 m possible
Weight:	22.0 kg/m ²

Construction material:

Frame construction made of aluminium, powder coated according to ZTV-ING part 4 appendix A, item 3.6.3

Acryl glass Soundstop (EVONIK PARA-CHEMIE GmbH)
 $R_w = 32$ dB (DIN EN ISO 717-1) $DL_R = 30$ dB (DIN EN 1793-2)

Transverse profiles made of folded aluminium
Vertical sealing with EPDM joint.

Typ: FAIST View A(P)
Transparent sound barrier wall panel, optionally with polyamide filaments

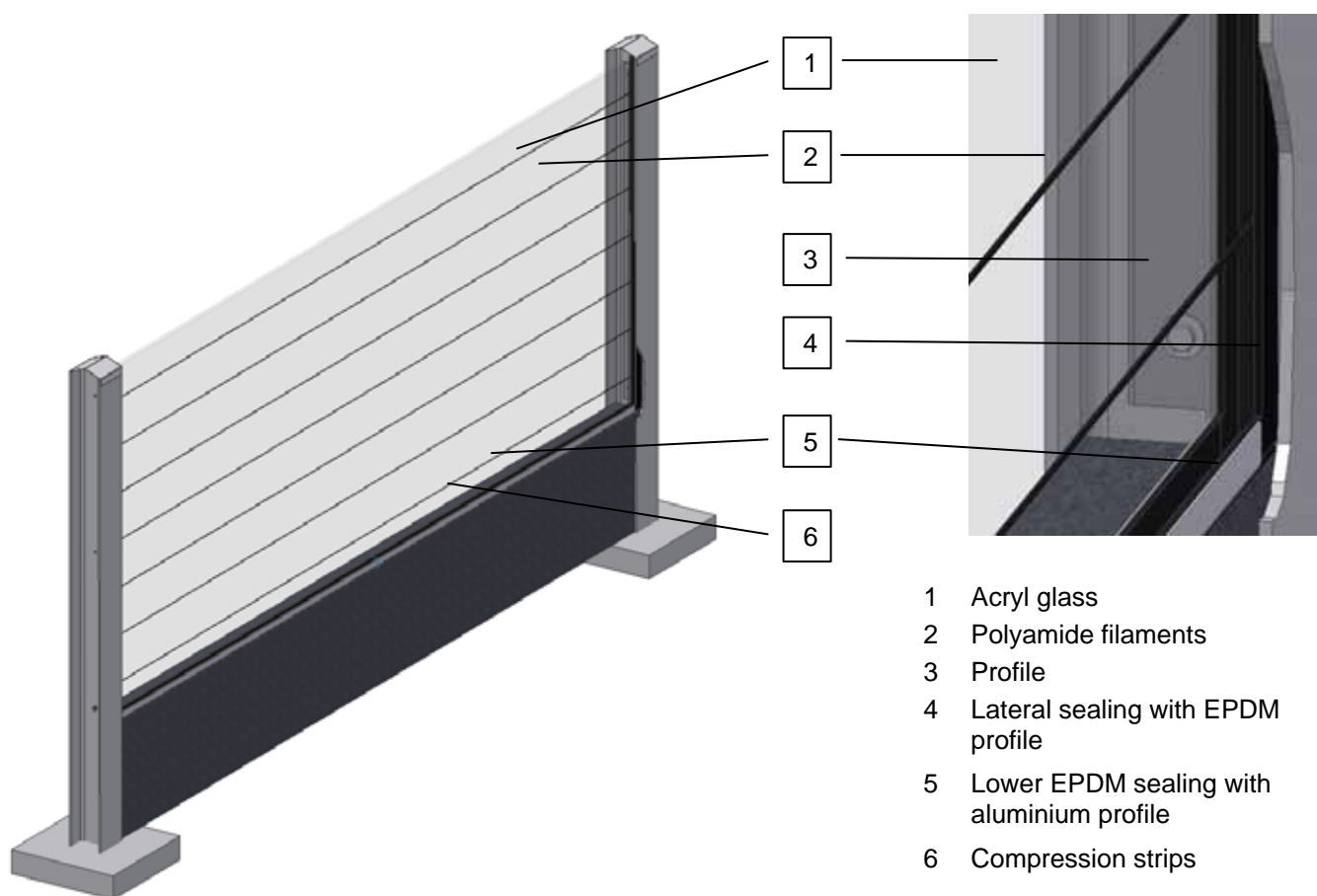

Basic material:

Acryl-glass: glass thickness 15 mm or 20 mm
 Optionally with fused polyamide filaments or with screen print.

Description:

Transparent noise-proofing panel, reflective, according to ZTV_LSW 88, ZTV-LSW 06, EN 1793 1-3 and EN 1794 1-2
 Underside bordered in EPDM sealing with aluminium profile, lateral sealing with angle-profile and EPDM profile.

Dimensions:

max. 4000 x 2000 mm (L x H)
 max. 2000 x 4000 mm (L x H)

Air borne noise reduction:

15 mm $DL_R = 30 \text{ dB}$
 20 mm $DL_R = 32 \text{ dB}$

FAIST sound barrier wall panel with safety rope

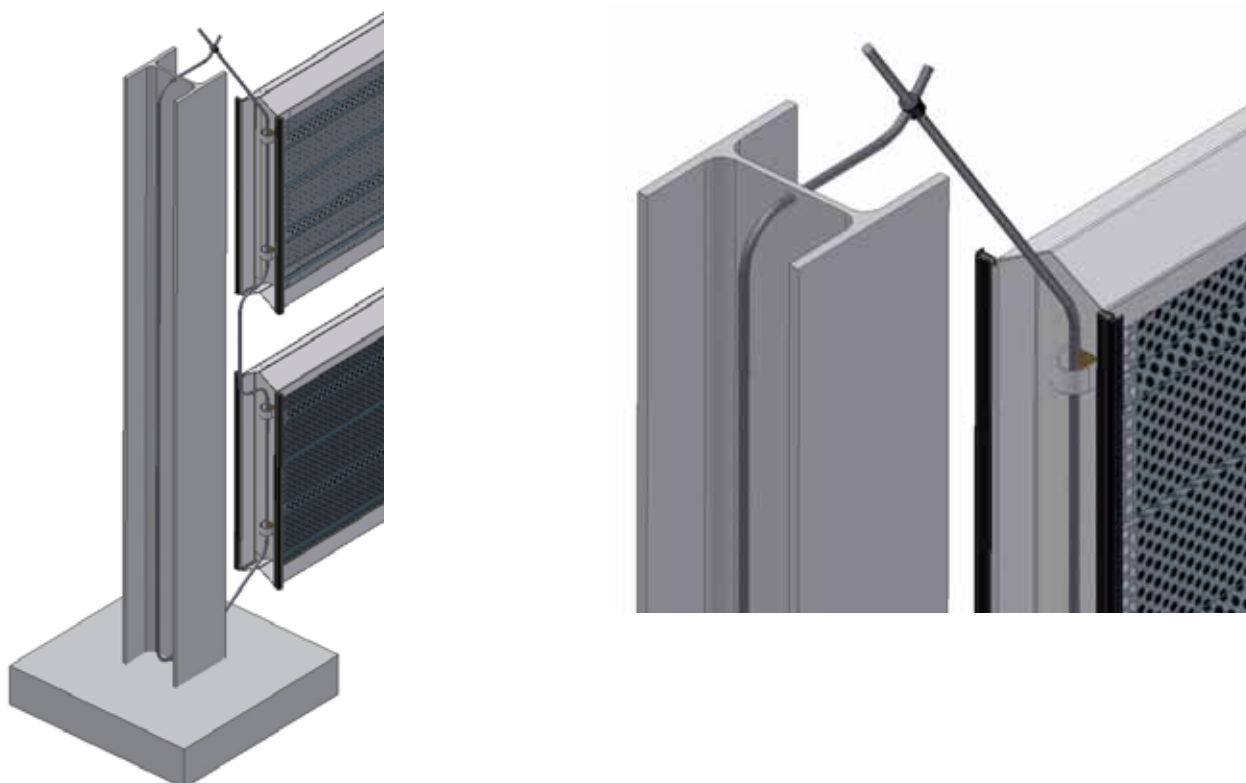

On bridges, retaining walls and similar exposed positions above traffic places, sound barrier panels have to be secured against dropping by means of retaining devices (e.g. safety ropes)

As a rule, the retaining devices have to be put on the four corners of each wall panel.

FAIST – Safety ropes feature all necessary characteristics, such as:

- Suitable for a minimum load of 10 kN
- The length of the rope loop is designed in a way to retain the soundproofing panel after a displacement of 0.3 m.
- Rope and fastening devices are manufactured of stainless steel according to DIN 17 440 material no. 1.4401 or 1.4572
- Rope diameter 4 mm and more

Valid Standards Regarding Noise Control

- DIN EN 1793-1: Road traffic noise reducing devices. Test method for determining the acoustic performance – Part 2: intrinsic characteristics of sound absorption.
- DIN EN 1793-2: Road traffic noise reducing devices – Test method for determining the acoustic performance – Part 2: Intrinsic characteristics of airborne sound insulation.
- DIN EN 1793-3: Road traffic noise reducing devices – Test method for determining the acoustic performance – Part 3: Normalised traffic noise spectrum.
- DIN EN 1794-1: Road traffic noise reducing devices – Non-acoustic performance – Part 1: Mechanical performance and stability requirements.
- DIN EN 1794-2: Road traffic noise reducing devices – Non-acoustic performance – Part 2: General safety and environmental requirements.
- ZTV-LSW 88: Additional specifications and directives for the construction of sound barriers walls at roads
- ZTV-LSW 06: Additional technical contractual conditions and directives for the construction of sound barrier walls at roads